

AxisTM415 Motorised Drum

General Features

- Diameter Ø415mm
- Helical gear unit with steel tothing
- Standard length from 540mm to 1400mm
- Three-phase motors
- 3 kilowatt to 15 kilowatt input power
- Insulation class F
- Mild steel or stainless steel construction
- Lubricated with synthetic oil
- Terminal box connection
- Special options available
- Quality European manufacture



TM415 Dimensions

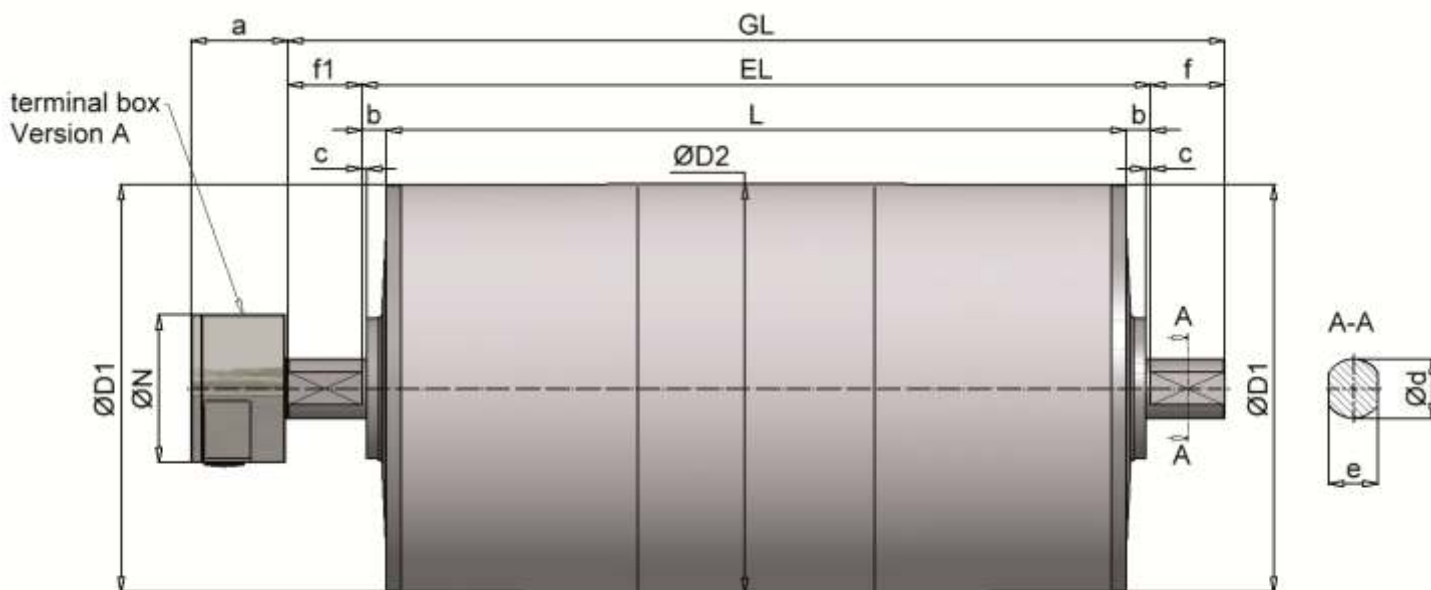

Dimensions in mm

		DRUM MOTOR									STANDARD IP66		OPTIONAL IP67	
Size	Type	Ø D1	Ø D2*	a	Ø N	c	Ø d	e	f	f1	b	EL	b	EL
415	TM 415.0	413	415	95	112	3	45	35	53	53	22	L + 44	32	L + 64
415	TM 415.1	413	415	100	150	5	60	50	75	75	25	L + 50	35	L + 70
		GUIDE DRUM												
415	UT 415.0	413	415			3	45	35	53		22	L + 44	32	L + 64
415	UT 415.1	413	415			5	60	50	75		25	L + 50	35	L + 70

* Diameter with cylindrical drum design

AxisTM415 Motorised Drum

TM415 Performance Data

Type	POWER	BELT SPEED	ROTATION SPEED	BELT PULL	TORQUE	POWER INPUT AT 400V / 50Hz	DRUM LENGTH	WEIGHT
		v	n2	F	T2		L min.	L=750mm
	[kW]	[m/s]	[1/min]	[N]	[Nm]		[mm]	[kg]
TM415.0	3,00 4-pole	0,78	36	3857	800	3,20	550	160
		0,95	44	3148	653			
		1,32	61	2276	472			
		1,61	74	1858	386			
TM415.1	4,00 4-pole	0,60	28	6678	1386	9,00	750	275
TM415.0		0,84	39	4746	985		550	170
		0,95	44	4227	877			
		1,31	60	3056	634			
		1,60	74	2495	518			
		2,08	96	1923	399			
TM415.1	5,50 4-pole	0,87	40	6344	1316	11,50	750	290
TM415.1		1,04	48	5267	1093			
		1,29	59	4266	885			
		1,56	72	3530	733			
		1,72	79	3201	664			
		2,17	100	2534	526			
TM415.1	7,50 4-pole	1,04	48	7182	1490	15,50	750	300
TM415.1		1,29	59	5818	1207			
		1,56	72	4814	999			
		1,72	79	4365	906			
		2,17	100	3456	717			
TM415.1	10,00 4-pole	1,28	59	7811	1621	21,00	750	320
TM415.1		1,55	71	6464	1341			
		1,71	79	5861	1216			
		2,16	99	4640	963			
TM415.1	15,00 4-pole	1,71	79	8792	1824	29,50	750	360
TM415.1		2,16	99	6959	1444			

- alternative performance data and speeds on request
- indication of weight incl. oil filling (ready for operating)
- additional weight: approx. 10,0kg for 100mm add. length
- with brake mounting L min. dimension raises up 200mm



AxisTM415 Design & Options

Standard Configuration

- Crowned shell, mild steel with rust protection paint
- Bearing covers made of cast iron
- Shafts made of mild steel with rust protection paint
- Helical gear unit with steel toothing (quiet)
- IP66 protection rating
- Terminal box
- Colour RAL 2004

Options

- Internal brake
- Mechanical backstop
- Sprocket / toothed belt disc
- Cylindrical drum shell, rubber coated, zinc plated (customised)
- Stainless steel design
- Thermal contact
- IP67 protection
- Suitable for frequency converter use
- Terminal box design in stainless steel
- Vertical mounting (should be stated in the order)
- Food-safe lubricant

Alternative custom designs also available - please enquire

TM415 Clamping Bearing

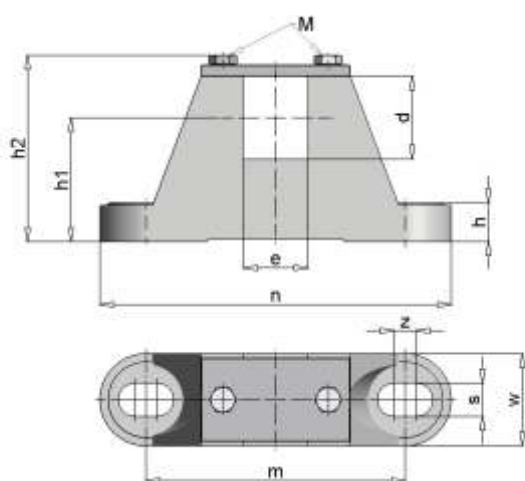

dimensions in mm

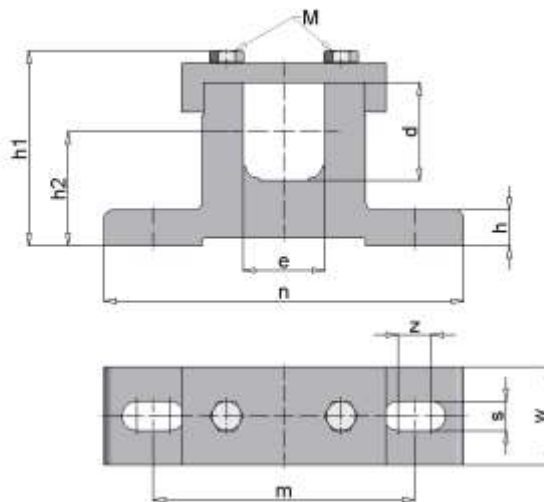

DRUM TYPE	CLAMPING BEARING	d	e	h	h1	h2	m	n	s	w	z	M	MATERIAL	ca. kg
TM/UT 415.0	EL45/35	45	35	21	67	105	140	190	18	50	12	M8	Cast iron	2,8
TM/UT 415.1	EL60/50	60	50	22	70	119,5	160	220	18	60	20	M12	Steel	5

